



ABSOLUTE ROTARY ENCODER MODBUS/TCP



Main Features

- Compact and heavy duty industrial model
- Communication via standard protocols
- Integrated web server
- Interface: Modbus/TCP
- Housing: 58 mm Ø
- Full shaft: 6 or 10 mm Ø /
hollow shaft 15 mm Ø
- Resolution: max. 30 Bit = 1,073,741,824
steps over 16384 revolutions
- Code: Binary

Programmable Parameters

- Used scope of physical resolution
- Total scaled resolution
- Preset value
- Direction of rotation (complement)
- Different modes for output of position, velocity
and time stamp
- Network- and e-mail- parameters

Mechanical Structure

- Flange and housing, Aluminum and Brass
respectively
- Stainless steel shaft
- Precision ball bearings with sealing rings
- Code disc made of durable and unbreakable
plastic
- Robust electrical connection with M12-connector

Electrical Features

- Status indication with LEDs
- Temperature insensitive
IR-Opto-receiver-ASIC
- Polarity inversion protection
- Over-voltage-peak protection



ABSOLUTE ROTARY ENCODER MODBUS/TCP

Technical Data

Electrical Data

Supply voltage	10 - 30 V DC (absolute limits)
Power consumption	max. 4 Watt
EMC	Emitted interference: EN 61000-6-4
	Noise immunity: EN 61000-6-2
Bus connection	Modbus/TCP
Transmission rate	10/100 MBit
Accuracy of division	$\pm \frac{1}{2}$ LSB (up to 12 Bit), ± 2 LSB (up to 16 Bit)
Step frequency LSB	max. 800kHz (valid code)
Cycle time	> 1 ms (Cyclic mode), > 5 ms (Change of state) for TCP/IP > 5 ms for Modbus/TCP
Electrical lifetime	> 10 ⁵ h
Device addressing	Programmable IP-Address and Network parameters

Mechanical Data

Housing	Aluminum, optional stainless steel			
Lifetime	Dependent on shaft version and shaft loading – refer to table			
Max. shaft load	Axial 40 N, radial 110 N			
Inertia of rotor	$\leq 30 \text{ gcm}^2$			
Friction torque	$\leq 3 \text{ Ncm}$ (without shaft sealing)			
RPM (continuous operation)	max. 12,000 RPM			
Shock (EN 60068-2-27)	$\leq 30 \text{ g}$ (halfsine, 11 ms)			
Permanent shock (EN 60028-2-29)	$\leq 10 \text{ g}$ (halfsine, 16 ms)			
Vibration (EN 60068-2-6)	$\leq 10 \text{ g}$ (10 Hz ... 1,000 Hz)			
Weight (standard version)	Singleturn: $\approx 500 \text{ g}$			
	Multiturn: $\approx 700 \text{ g}$			
Flange	Synchro (S)		Clamp (C)	Hollow shaft (B)
Shaft diameter	6 mm	10 mm	10 mm	15 mm
Shaft length	10 mm	20mm	20 mm	-
hollow shaft depth min. / max.	-	-	-	15 mm / 30 mm



ABSOLUTE ROTARY ENCODER MODBUS/TCP

Minimum (mechanical) lifetime

Flange	Lifetime in 10 ⁸ revolutions with F _a / F _r		
	40 N / 60 N	40 N / 80 N	40 N / 110 N
C10 (Clamp flange 10 x 20)	247	104	40
S10 (Synchro flange 10 x 20)	262	110	42
S6 (Synchro flange 6 x 10) without shaft sealing	822	347	133

S6 (Synchro flange 6 x 10) with shaft sealing: max. 20 N axial, 80 N radial

Environmental Conditions

Operating temperature	0 .. +60°C
Storage temperature	- 40 .. + 85 °C
Humidity	98 % (without liquid state)
Protection class (EN 60529)	Casing side: IP 65
	Shaft side: IP 64 (optional with shaft sealing: IP66)



ABSOLUTE ROTARY ENCODER MODBUS/TCP

Interface

Protocols

The communication is based on Modbus/TCP at data rates of 10 Mbps or 100 Mbps. TCP/IP stacks are available in all common operating systems. A data exchange in heterogeneous networks is possible by using the IP protocol. The control system send commands to and receive data from the Encoder by the exchange of commands in ASCII text. Java Applets providing a graphical user interface (GUI) and documentation is provided on a Web server integrated in the Encoder for convenient configuration and diagnosis. Based on

http, html and Java applets the GUI and all documents can be displayed on all common web browsers. In addition to the encoder parameters all necessary network parameters, like the IP-address, can be set. All parameters are saved in a non volatile memory so that the configuration is available promptly after a restart. Another feature of the web server is the optional output of messages via the SMTP protocol. In this way parameters and diagnosis messages can be sent by e-mail.

Modbus/TCP	The data will transports in the TCP-Frame. For detailed information's see the manual or on www.modbus.org .
IP	A data exchange in heterogeneous networks is possible by using the well known internet protocol "IP". The universal IP addressing simplifies the implementation of communication processes significantly.
TCP	TCP-Protocol assures an error free data transmission.
http	Via http a common web browser can be used for read out, configuration and diagnosis of the encoder with version A1.
smtp	Via smtp protocol messages of the encoder can simply be sent by e-mail with version A1.

ABSOLUTE ROTARY ENCODER MODBUS/TCP

Programmable Parameters

The encoder is able to provide three different kinds of output data: the position value, a velocity value and a time stamp. These can be used in arbitrary combinations. The following parameters can be modified:

Parameter	Description
Used scope of physical resolution (parameter 1.)	Specifies the part of the physical resolution used for the encoder in physical steps. If e.g. for an encoder with a resolution of 8,192 steps per revolution 16,384 is chosen, the encoder will count 8,192 steps per revolution (if "Total scaled resolution" is set to the same value as "Used scope of physical resolution") and start with zero again after 2 revolutions. If this value is not set to a value which results in an integer division with the total physical resolution, the encoder value will jump to zero when passing the physical zero point.
Total scaled resolution (parameter 2.)	Specifies the scaled resolution which is used over the area of physical steps defined by "Used scope of physical resolution". If e.g. the encoder is set as described above and "Total scaled resolution" is set to 10, the encoder will count 10 steps over the physical steps defined with "Used scope of physical resolution", i.e. 5 steps per revolution.
Code sequence	The parameter Code Sequence (Complement) determines whether the output code increases or decreases when the axis is turned clockwise.
Preset value	The preset value is the desired output value for the actual position of the axis. The actual output value will be set to this preset value.
Offset value	This variable makes it possible to directly change the offset calculated and set by the preset function.

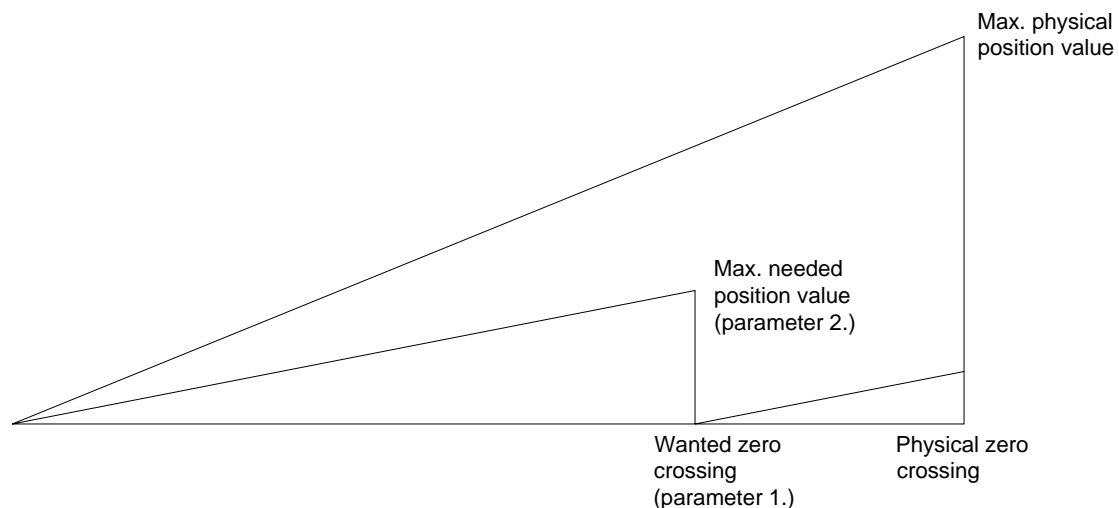



ABSOLUTE ROTARY ENCODER MODBUS/TCP

The integrated web server of the encoder contains different web pages for information purposes and to parameterize the encoder. The html-page for configuration and diagnostics of the encoder provides the following website:

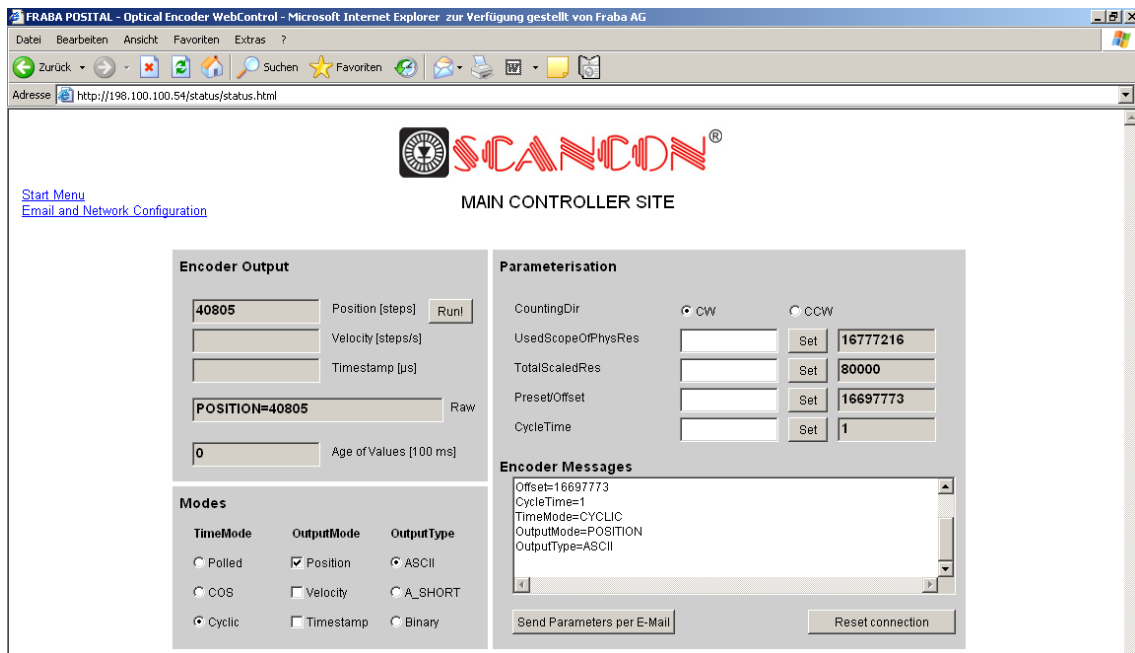

Pinning

Connector Ethernet

4 pin female, D-coded

Pin Number	Signal
1	Tx +
2	Rx +
3	Tx -
4	Rx -

Connector power supply

5 pin male, A-coded

Pin Number	Signal
1	+24 V
2	+24 V
3	0 V
4	0 V
5	PE

Sketch on encoder view

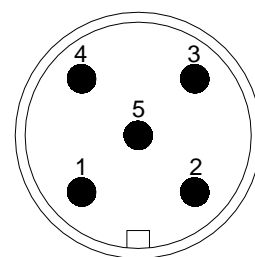
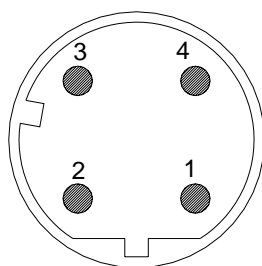

ABSOLUTE ROTARY ENCODER MODBUS/TCP

Hollow shaft (B)

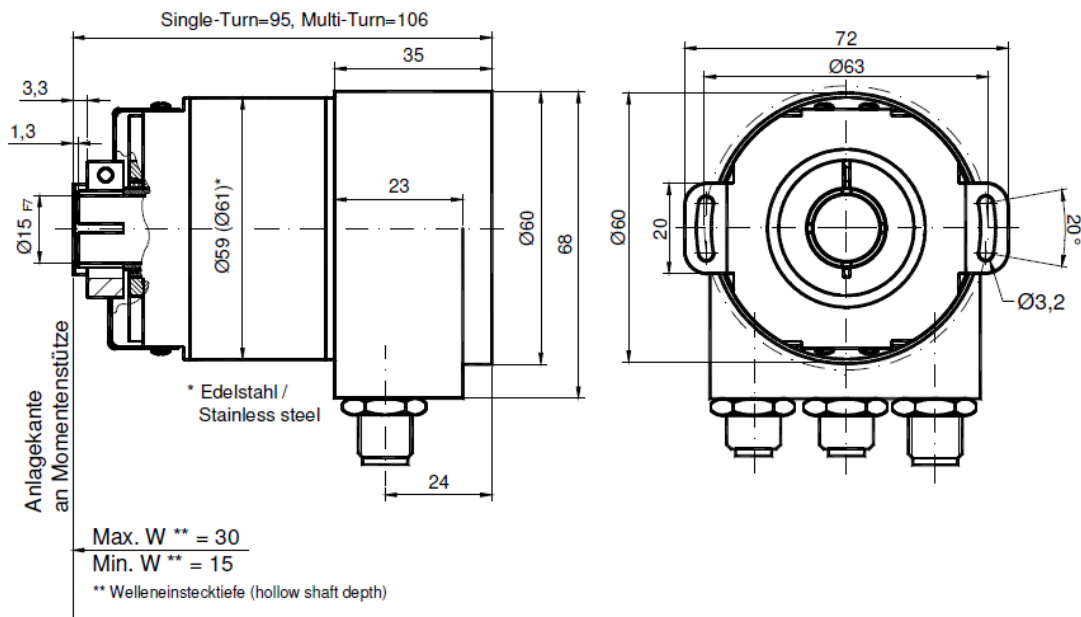

Mounting instructions

The clamp ring should only be tightened after the shaft of the driving element was inserted into the hollow shaft.

The diameter of the hollow shaft can be reduced to 12 mm, 10 mm or 8 mm by using an adapter (this reducing adapter can be pushed into the hollow shaft).

Maximum radial and axial misalignment of the drive shaft:

	axial	radial
static	± 0.3 mm	± 0.5 mm
dynamic	± 0.1 mm	± 0.2 mm



ABSOLUTE ROTARY ENCODER MODBUS/TCP

Models/Ordering Description

Description	Type Key							
Optocode	SAG-	EM	00	B -	-	-	-	- PRM
Interface	Ethernet	EM						
	Modbus/TCP							
Version	2xM12		00					
Code	Binary			B				
Revolutions	Singleturn						00	
(Bits)	Multiturn (4,096 revolutions)						12	
	Multiturn (16,384 revolutions)						14	
Steps per revolution	8,192						13	
	65,536						16	
Flange /	Clamp flange, full shaft:		Ø 10 mm				C10	
Shaft diameter	Synchro flange, full shaft:		Ø 6 mm				S06	
			Ø 10 mm				S10	
	Blind hollow shaft, hollow shaft :		Ø 15 mm				B15	
Mechanical options	Without						0	
	Shaft sealing (IP66)						S	
	Customized						C	
Connection	M12 connector							PRM

Standard = bold, further models on request



ABSOLUTE ROTARY ENCODER MODBUS/TCP

Accessories and Documentation

Description		Type
Male cable connector	M12, 4 pin, D-Coded	PAM4
Female cable connector	M12, 5 pin	PAM5
Coupling *	Drilling: Ø 10 mm	GS 10
	Drilling: Ø 6 mm	GS 06
Clamp disc *	Set = 4 pcs.	SP 15
Clamp half-ring *	Set = 2 pcs.	SP H
Reducing adapter **	15 mm to 14 mm	RR14
	15 mm to 12 mm	RR12
	15 mm to 11 mm	RR11
	15 mm to 10 mm	RR10
	15 mm to 8 mm	RR8
User manual *	Installation / configuration manual, English	UMD-EM
User manual *	Installation / configuration manual, German	UME-EM

* These can be downloaded free of charge from our homepage www.scancon.dk

** usable only for full shaft

*** usable only for hollow shaft, in stainless steel available too

We do not assume responsibility for technical inaccuracies or omissions. Specifications are subject to change without notice.